

# the wetseat

neoprene seatcovers

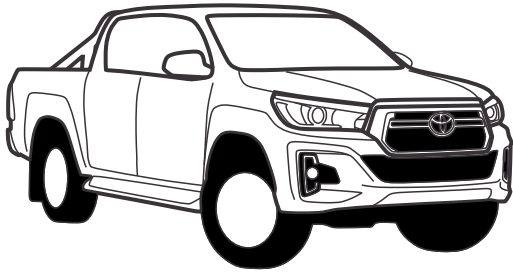

a product of **INLAND**  
AUSTRALIA PTY LIMITED

This seat cover suits the **TOYOTA HILUX GEN.8 (09/2015-Current) ONLY**

## Important



- Do not fit these seat covers to any other vehicle.
- Please read these instructions carefully and install seat covers exactly as described.
- Regularly inspect seat covers for any wear or misalignment which may cause damage to the seat covers.
- Adjust alignment if seat cover twists or moves from its original, centrally aligned position.
- As with all garment type products the threads will give if pulled on too hard. Use just enough force to align and pull the cover without breaking the sewn threads.
- Check that the cover does not impede the child restraint system or the seat belts and buckles.
- Place these fitting instructions in your glove box after installation for future reference.
- If you have any difficulty during installation, please call The Wetseat office for help.

## Care of your Wetseat covers

For light marks and surface dirt a damp cloth, chamois or wet wipes will suffice.

For heavier marks and stains machine wash your Wetseat,

Set to cold wash, gentle cycle using standard washing powder.

Dust off the covers first before putting them into a machine wash.

For salt water, sand or mud also try to hose down your Wetseat, cloth line dry in 1 hour  
(Ambient temp 20 degrees Celsius).

## Kit Contents

- 1 x Tailored Backrest Wet Seat Cover
- 2 x Tailored Cushion Wet Seat Covers
- 3 x Tailored Headrest Wet Seat Covers



the wetseat  
neoprene seatcovers

The Wetseat neoprene seat cover is a wet suit for your car seats. These innovative covers are designed for fitting onto all passenger vehicles. Catering for all seat types, so whether it is a 4x4, ute or the family wagon, The Wetseat is a versatile cover designed for the Australian way of life. The Wetseat is:

- UV Safe, Wont fade in the sunny Australian conditions
  - Water Resistant, Perfect for the beach, water sports, water crossings, fishing, camping, touring and more!
  - Dust, Dirt, Sand & Mud Resistant, wont let any of these seep through to your seat keeping your seats clean & dry!
  - Superior Comfort & Aesthetically Appealing
  - Abrasion and Chemical Resistant
  - Non Soiling and Non Static, Simple removal of dust and pet hair
- Australia's most trusted neoprene seat cover since 2007.

## Contact Us



Inland Australia Pty. Ltd.  
Unit 2/10c Childs Road.  
Chipping Norton.  
NSW. 2170. Australia



+61 2 9724 9499



[sales@thewetseat.com](mailto:sales@thewetseat.com)



[www.thewetseat.com](http://www.thewetseat.com)

Our mission is to provide locally developed, OEM quality products and services to our customers, driven by continuous improvement, innovation and research and development.

The Wetseat Neoprene Seat Covers - [www.thewetseat.com](http://www.thewetseat.com)

## REMOVE SEAT FROM VEHICLE

1. Lift both seat bases up (Fig. 1.1).

Remove centre seat belt from buckle under seat base (Fig 1.2).

Remove 5 bolts (Locations shown in Fig 1.1) from both sides of seat (Fig 1.3).

Lift Seat up and remove from vehicle.

Note that the seat is latched onto the firewall behind the 2 side headrests.

Remove all 3 (three) headrests.

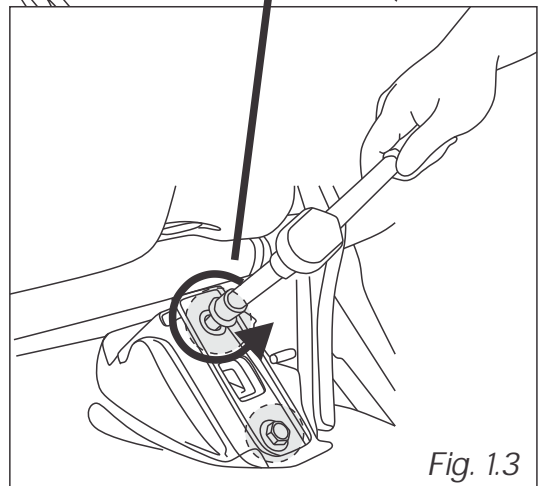
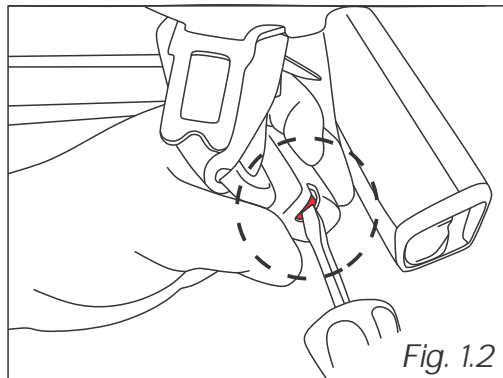
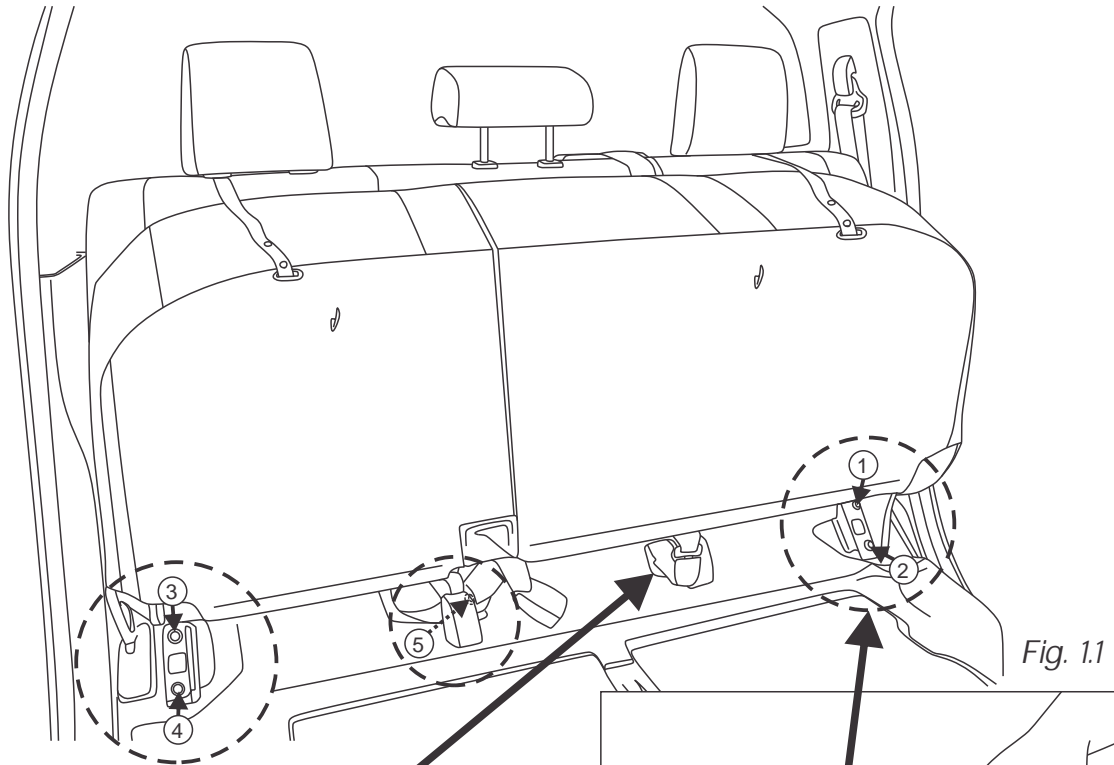

2. Tilt seat backrest forward and place backrest cover over the seat backrest (Fig. 2) .

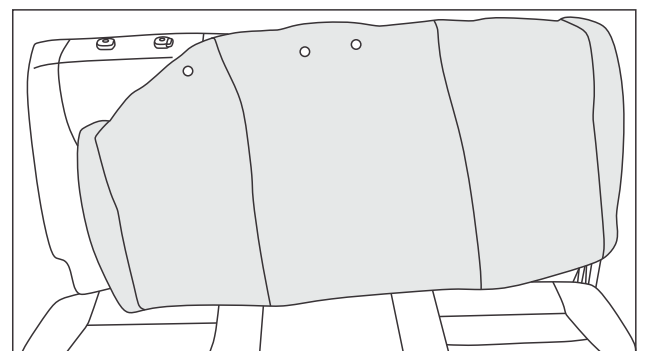

**IMPORTANT:**  
Do NOT pull too hard on the seat cover  
as it may cause threads to break.

3. Using your fingers, push backrest cover under headrest guide mechanisms to hold the top part of the backrest cover in place and centrally aligned.  
(Fig. 3)

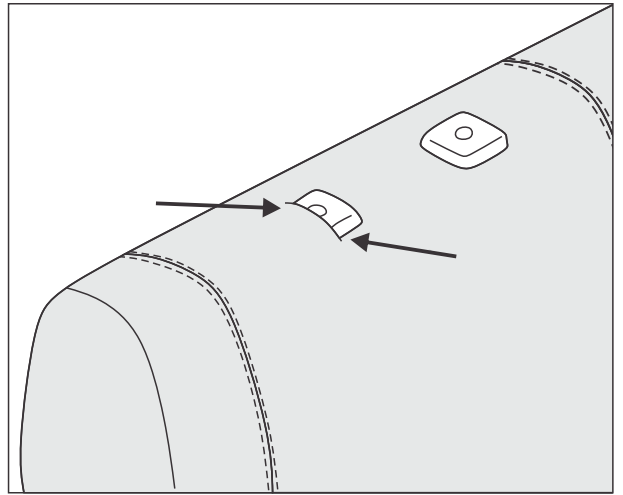

Fig. 3

4. For best fitment, work the backrest evenly and keep it aligned to the seats contours at all times. Once aligned, fold backrest forward and push the middle parts of the backrest cover through in between the seat backrest and base.  
(Fig. 4)

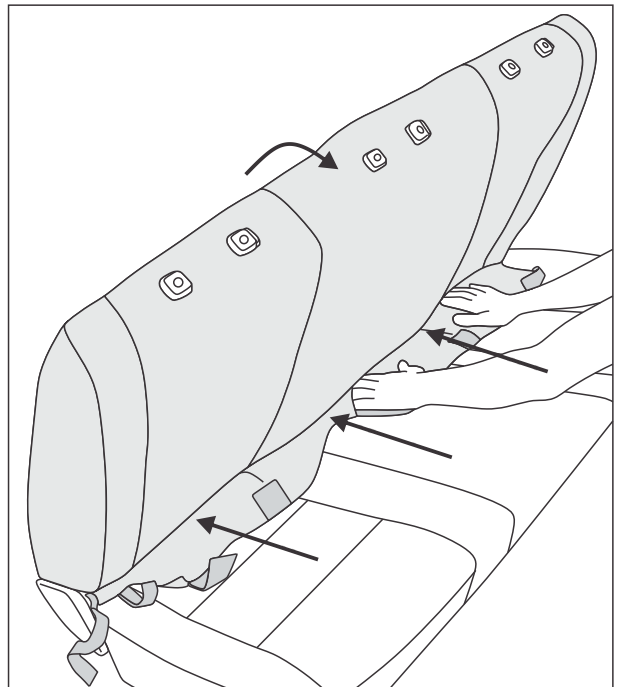

Fig. 4

5. Attach 6 clips to the back of the backrest.  
(Fig. 5)

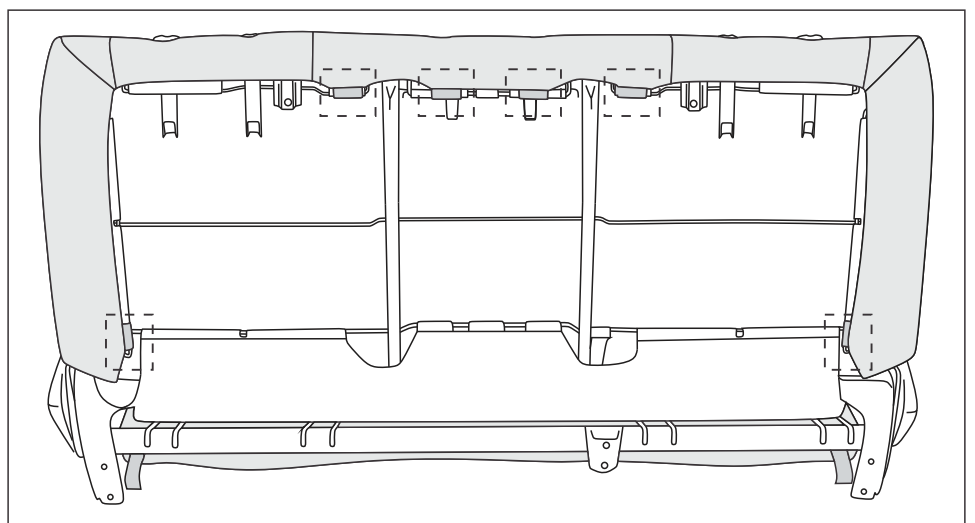

Fig. 5

6.1. Fold backrest down and place seat upright. Push tapes through near the corners of the seat (Fig.6.1).

Fig. 6.1



6.2. Push the corner of the seat (1) down to help push tapes through (Fig. 6.2). Push the 2 tapes (2 & 3) from the corner of the seat cover through (Fig. 6.2).

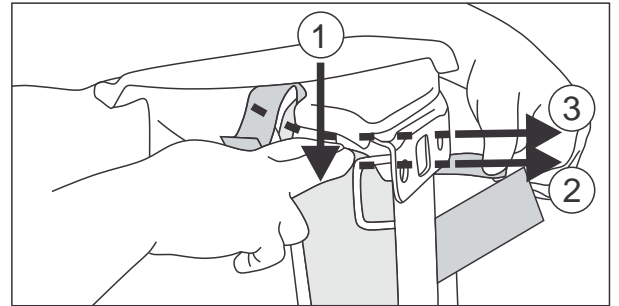

Fig. 6.2

6.3. Hold thicker hook tape (1) up and place loop tape (2) under it then attach thicker hook tape to back of backrest. Attach thinner hook tape (3) onto loop tape and back of the backrest (Fig. 6.3)

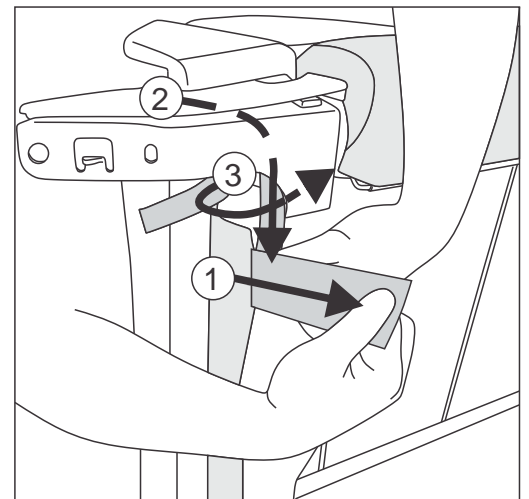

Fig. 6.3

6.4. Final attachment of 3 tapes in the corner of the backrest is shown in Fig 6.4. Repeat Steps 6.1-6.4 for other corner.

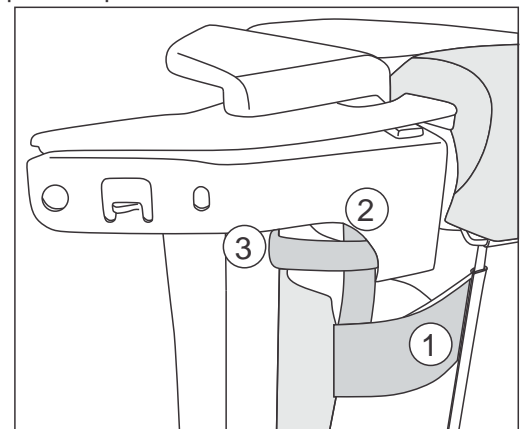

Fig. 6.4

6.5. Attach tapes in the middle of the backrest (Fig. 6.5).

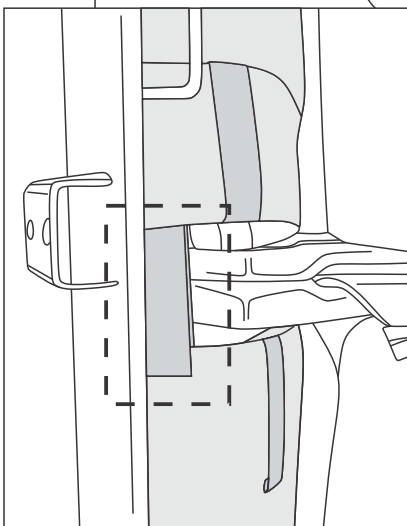

Fig. 6.5

## TAILORED BASE COVER INSTALLATION

7. Align base covers to the seats contours and roll around the edge of the seat.  
(Fig. 7)

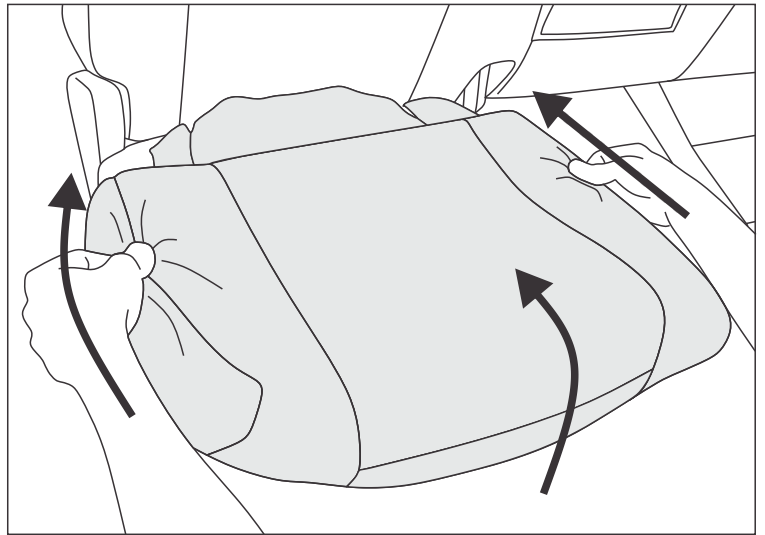

Fig. 7

8. Push the middle parts of the base cover through in-between the seat base and backrest.  
(Fig. 8)

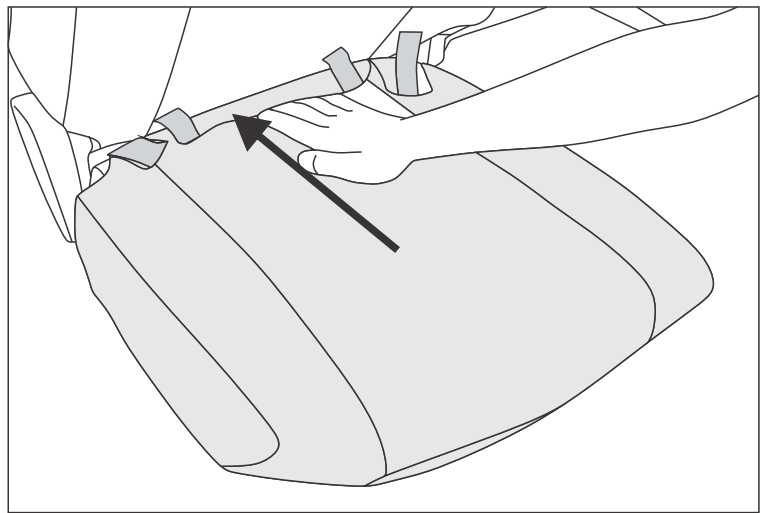

Fig. 8

9. Fold the seat bases up and attach the hook tapes underneath (Fig 9).

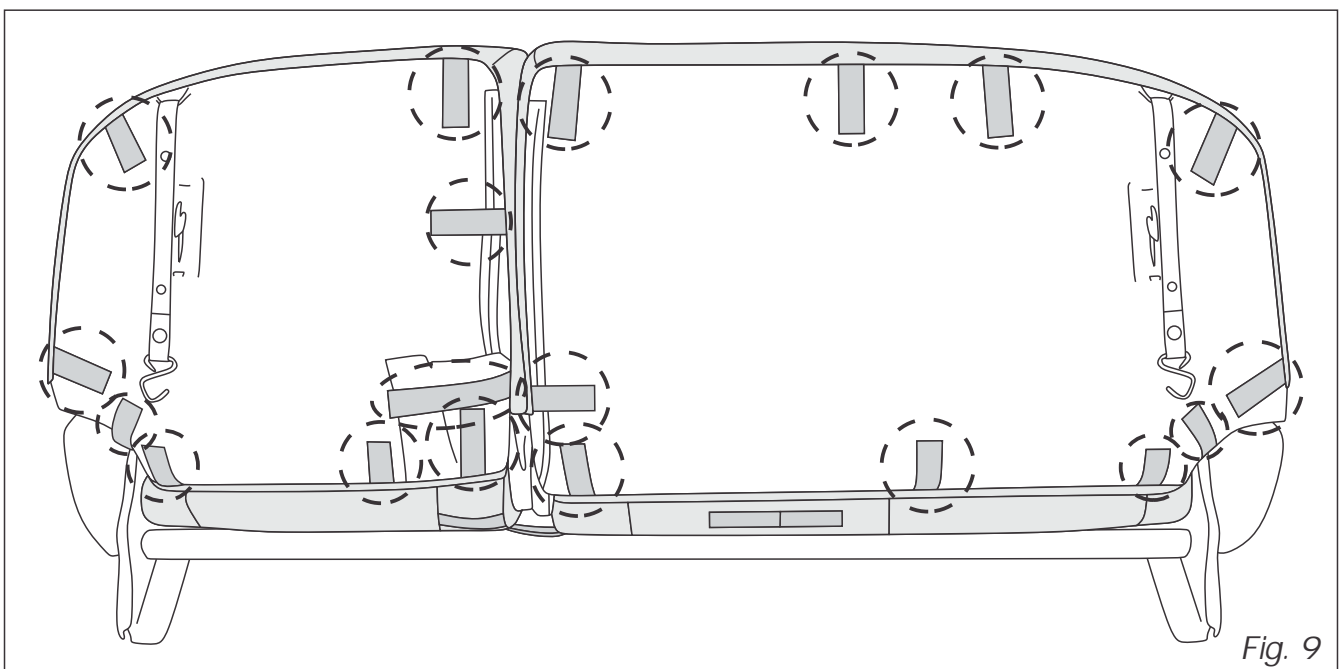

Fig. 9

## TAILORED HEADREST COVER INSTALLATION

10. Turn the headrest covers inside out and lay upside down on top of the headrest. Proceed to wrap the headrest cover over the headrest by rolling it down evenly. To make sure the headrest cover is being fitted correctly, ensure the seams are aligned before rolling it down. Once fitted, attach the hook and loop tapes underneath (Fig. 10).

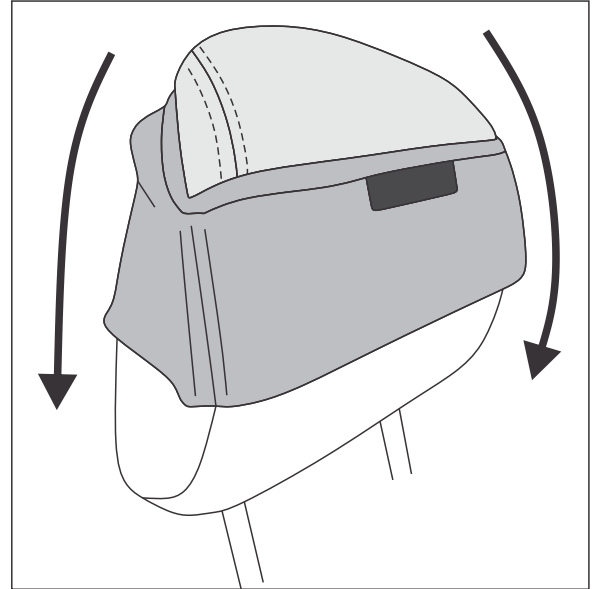

Fig. 10

11. To install the headrest covers, wrap the cover over the headrest from the back to the front keeping it aligned at all times (Fig. 11).

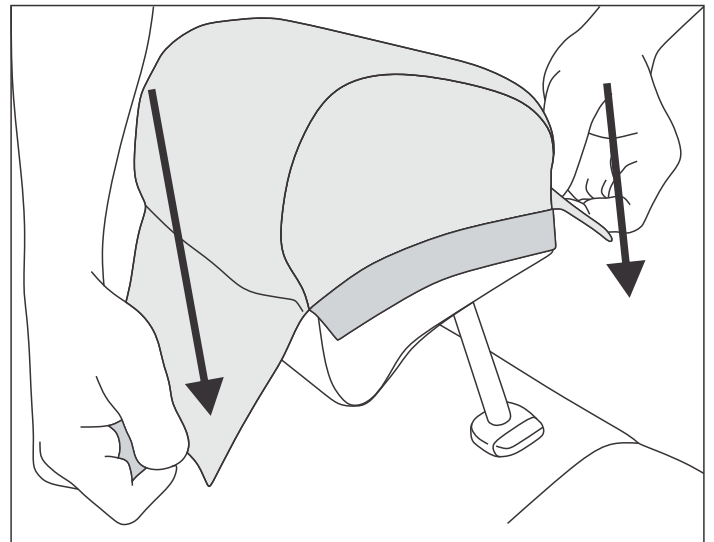

Fig. 11

12. Attach the hook and loop tapes underneath. (Fig. 12)

13. Re-install all 3 headrests to the seat backrest.

14. Re-install seat into vehicle by lifting cushion up and placing the backrest back onto the hinges. Re-do the 5 bolts that were taken off in Step 1. Re-click the centre seat belt in.

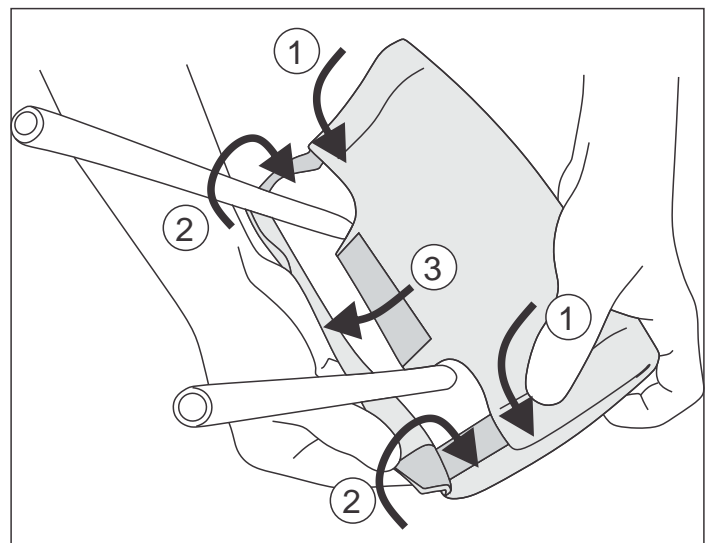

Fig. 12